

circuit diagram

H348

Cable colors unless otherwise noted:

red (rd): DC +

black (bk): DC -

brown (br): AC L

blue (bl): AC N

green/yellow (gn/ye): AC Ground

All cable cross-sections unless otherwise noted: 1,5mm²

01	new Sentinel Boats Monitor	26.06.2019	DW	Datum	17.07.2017		Hanse Yachts AG Salinenstr. 22 17489 Greifswald	cover sheet	=	+	Blatt: 1
00	release	02.01.2018	JT	Gezeichnet	B. Gladrow						
				Geprüft	T. Stein						
Rev.	Änderung	Datum	Name	Genehmigt	T. Stein				Hanse 348	H16A-7215-100-010 -01	von 26 Bl.

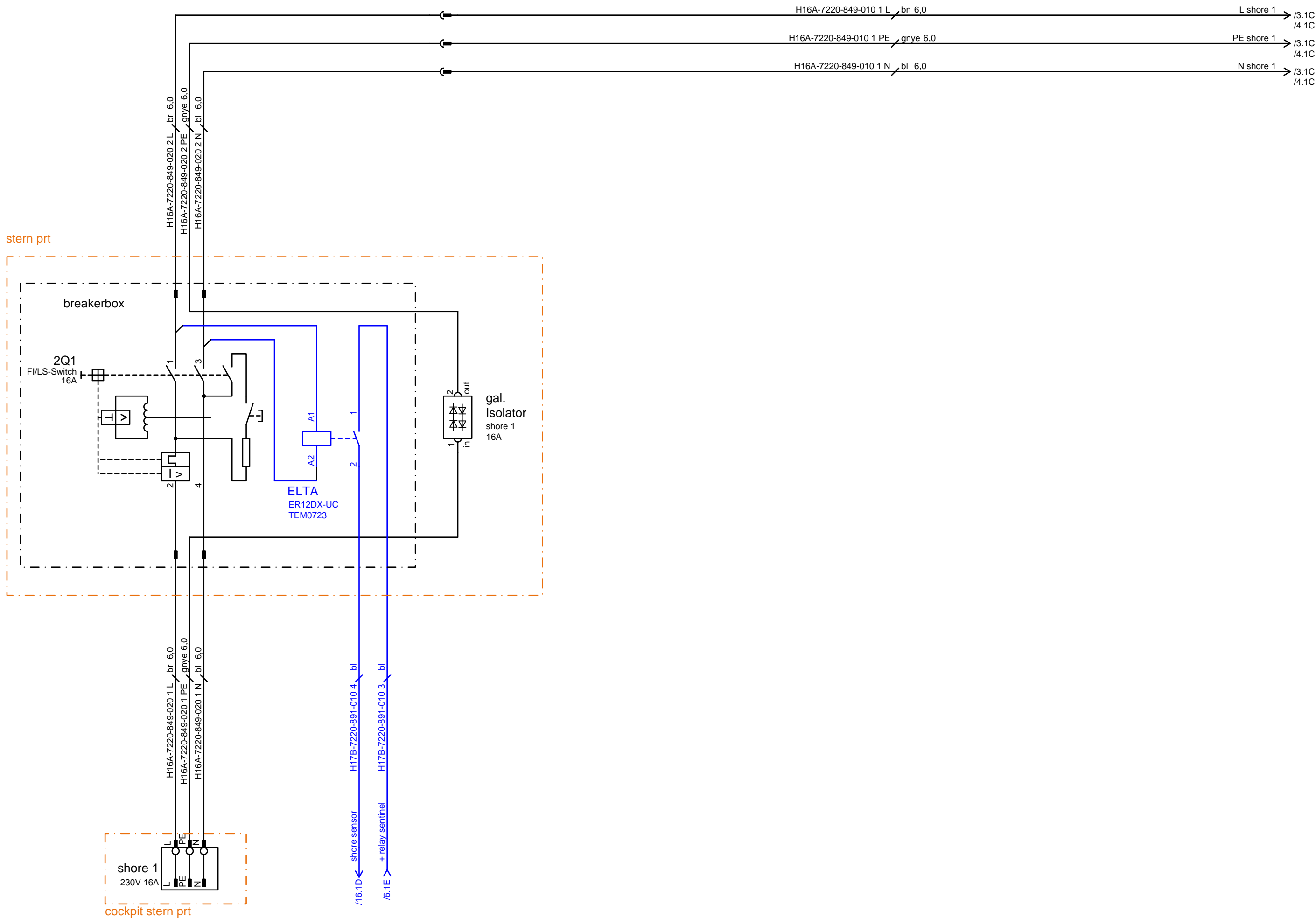

01	new Sentinel Boats Monitor	26.06.2019	DW	Datum	17.07.2017
00	release	02.01.2018	JT	Gezeichnet	B. Gladrow
				Geprüft	T. Stein
Rev.	Änderung	Datum	Name	Genehmigt	T. Stein



Hanse Yachts AG
Salinenstr. 22
17489 Greifswald

AC Circuits
Shore Power

=			
+			
Hanse 348	H16A-7215-100-010 -01	Blatt:	2
		von 26	Bl.

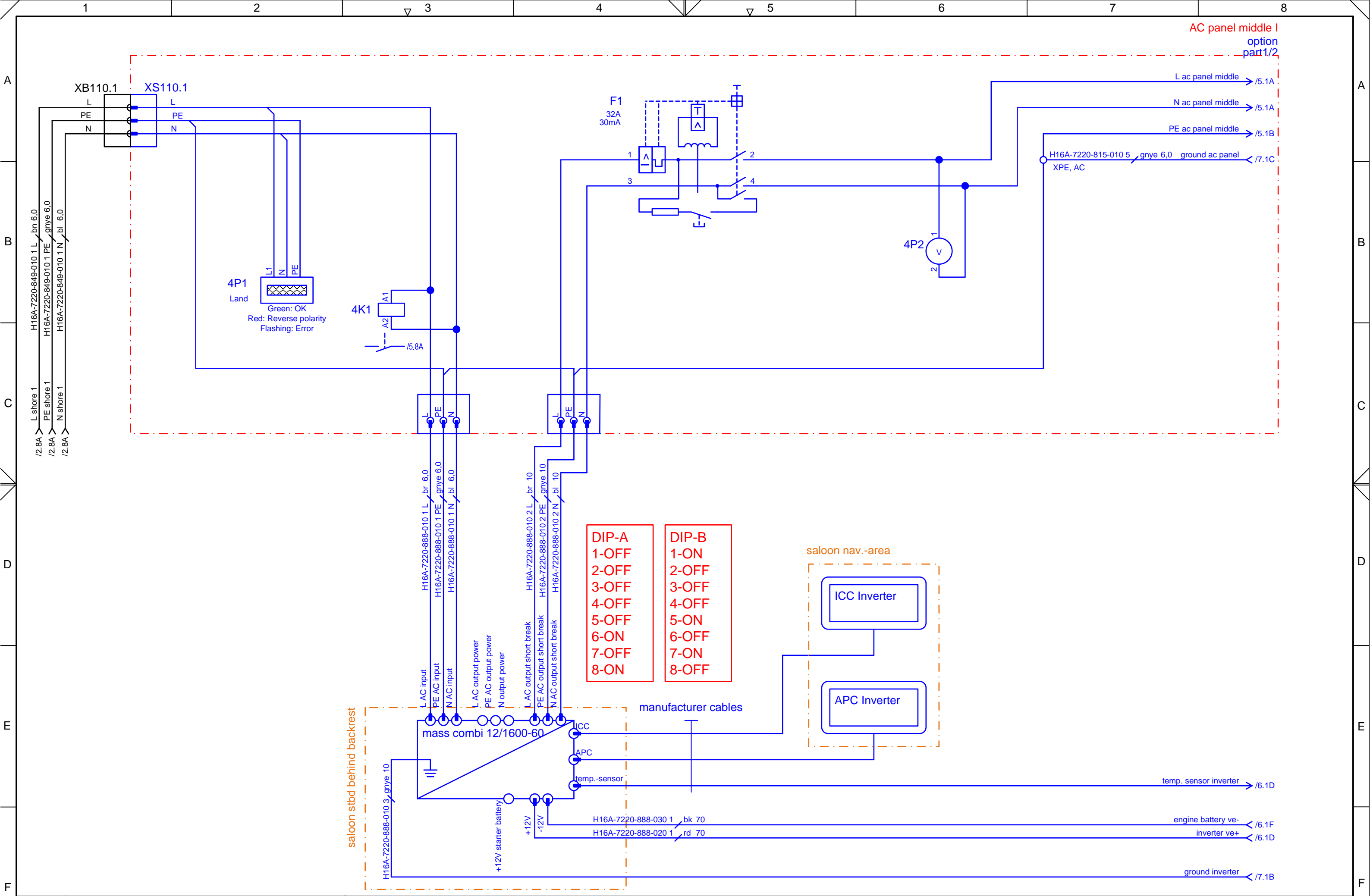

- | | |
|--------------|--------------|
| DIP-A | DIP-B |
| 1-OFF | 1-ON |
| 2-OFF | 2-OFF |
| 3-OFF | 3-OFF |
| 4-OFF | 4-OFF |
| 5-OFF | 5-ON |
| 6-ON | 6-OFF |
| 7-OFF | 7-ON |
| 8-ON | 8-OFF |

01	new Sentinel Boats Monitor	26.06.2019	DW	Datum	17.07.2017
00	release	02.01.2018	JT	Gezeichnet	B. Gladrow
Rev.	Änderung	Datum	Name	Geprüft	T. Stein
				Genehmigt	T. Stein



Hanse Yachts AG
Salinenstr. 22
17489 Greifswald

AC Circuits
AC Panel middle Part 1

Hanse 348	H16A-7215-100-010 - 01	Blatt: 4
		von 26 Bl.

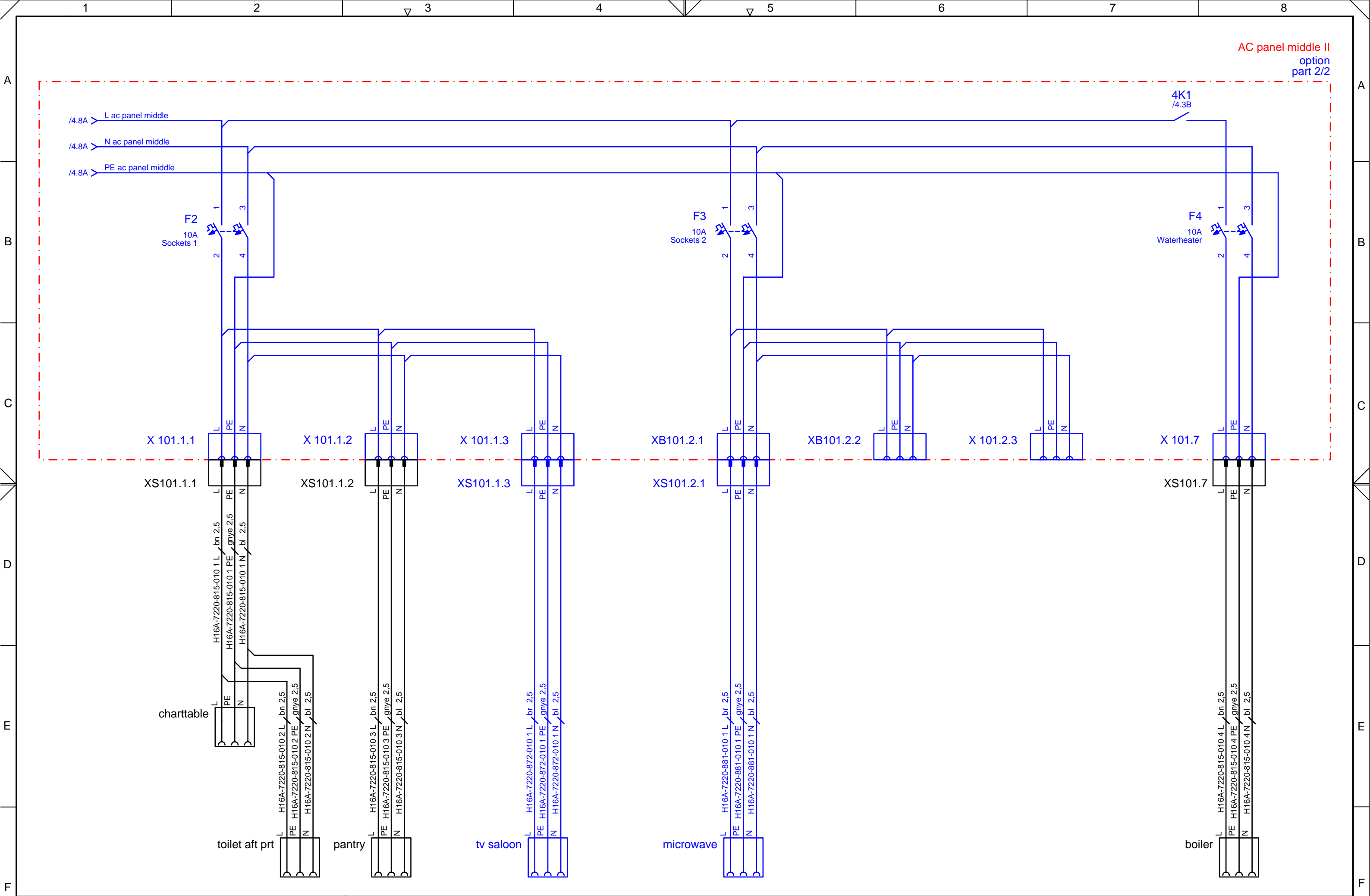

AC panel middle II
option
part 2/2

01	new Sentinel Boats Monitor	26.06.2019	DW	Datum	17.07.2017
00	release	02.01.2018	JT	Gezeichnet	B. Gladrow
				Geprüft	T. Stein
Rev.	Änderung	Datum	Name	Genehmigt	T. Stein



Hanse Yachts AG
Salinenstr. 22
17489 Greifswald

AC Circuits
AC Panel middle Part 2

=			
+			
Hanse 348	H16A-7215-100-010 - 01	Blatt:	5
		von 26	Bl.

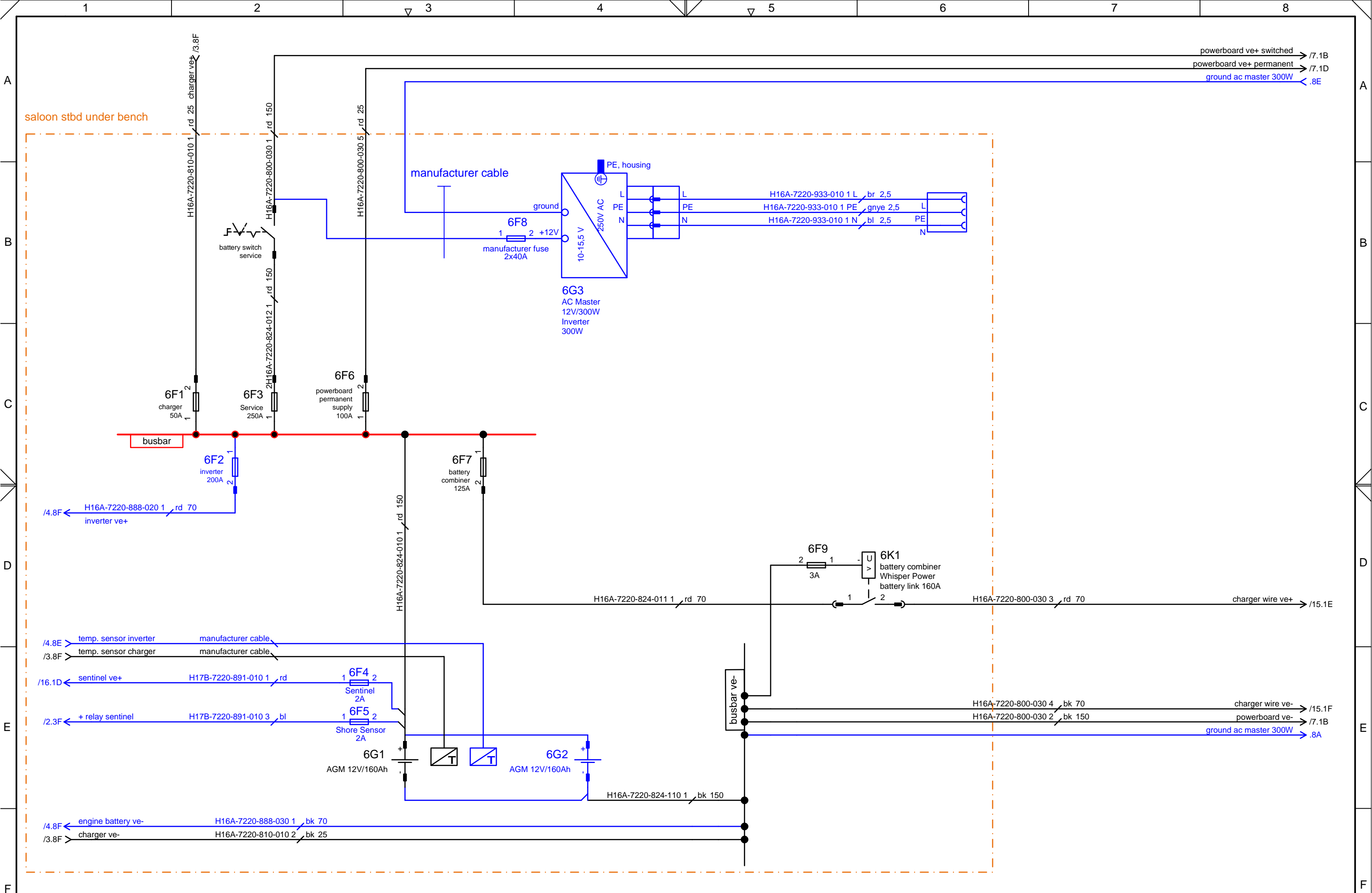

saloon stbd under bench

01	new Sentinel Boats Monitor	26.06.2019	DW	Datum	20.07.2017
00	release	02.01.2018	JT	Gezeichnet	B. Gladrow
				Geprüft	T. Stein
Rev.	Änderung	Datum	Name	Genehmigt	T. Stein



Hanse Yachts AG
Salinenstr. 22
17489 Greifswald

DC Circuits
Service

Hanse 348		H16A-7215-100-010 - 01		Blatt:	6
				von	26
					Bl.

Powerboard V2, small version, part 1

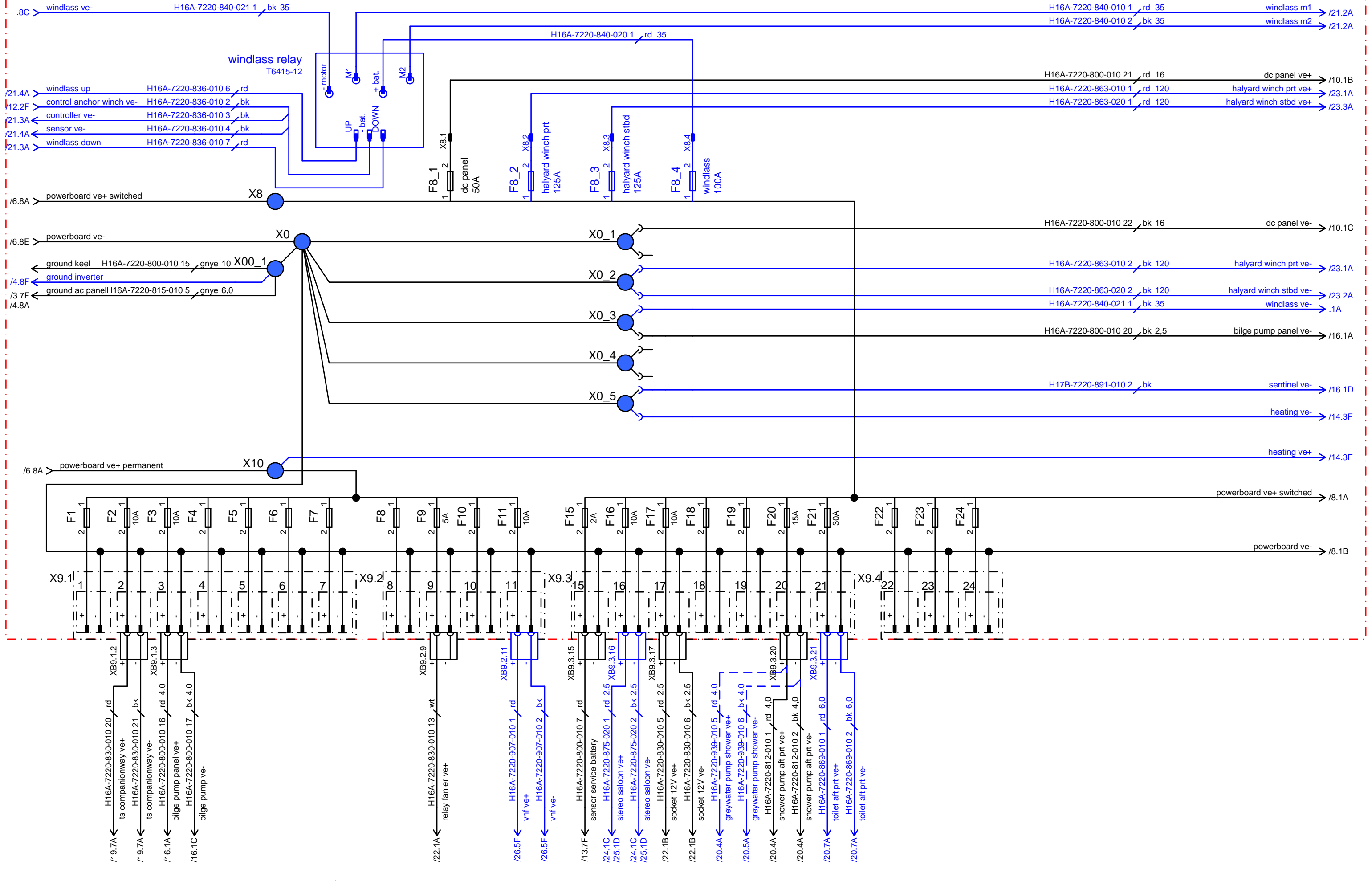

01	new Sentinel Boats Monitor	26.06.2019	DW	Datum	20.07.2017
00	release	02.01.2018	JT	Gezeichnet	B. Gladrow
Rev.	Änderung	Datum	Name	Geprüft	T. Stein
				Genehmigt	T. Stein



Hanse Yachts AG
Salinenstr. 22
17489 Greifswald

DC Circuits
Powerboard Part 1

Hanse 348		H16A-7215-100-010 - 01		Blatt: 7
				von 26 Bl.

Powerboard V2, small version, part 2

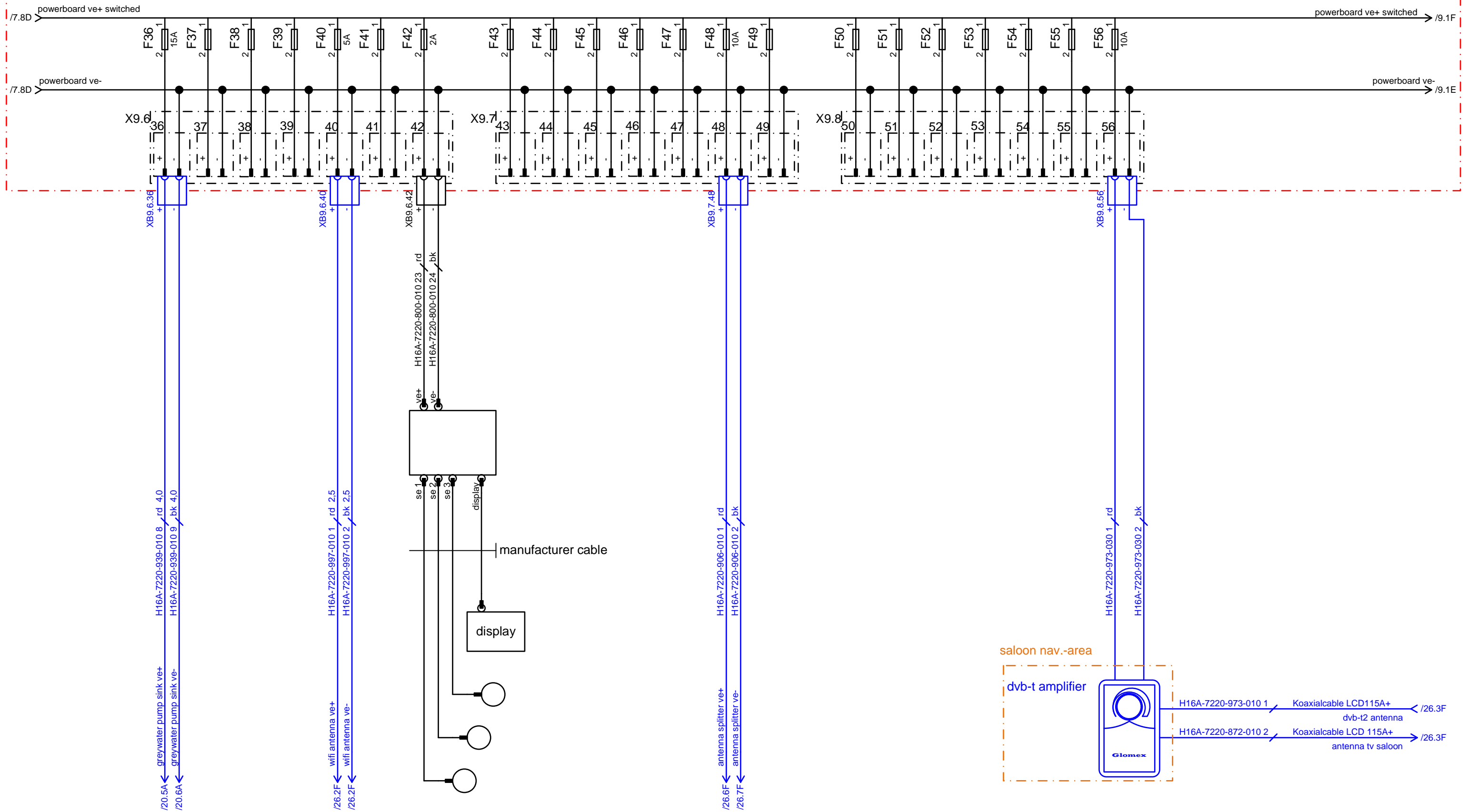

01	new Sentinel Boats Monitor	26.06.2019	DW	Datum	24.07.2017
00	release	02.01.2018	JT	Gezeichnet	B. Gladrow
Rev.	Änderung	Datum	Name	Geprüft	T. Stein
				Genehmigt	T. Stein



Hanse Yachts AG
Salinenstr. 22
17489 Greifswald

DC Circuits
Powerboard Part 2

=			
+			
Hanse 348	H16A-7215-100-010 -01	Blatt:	8
		von 26	Bl.

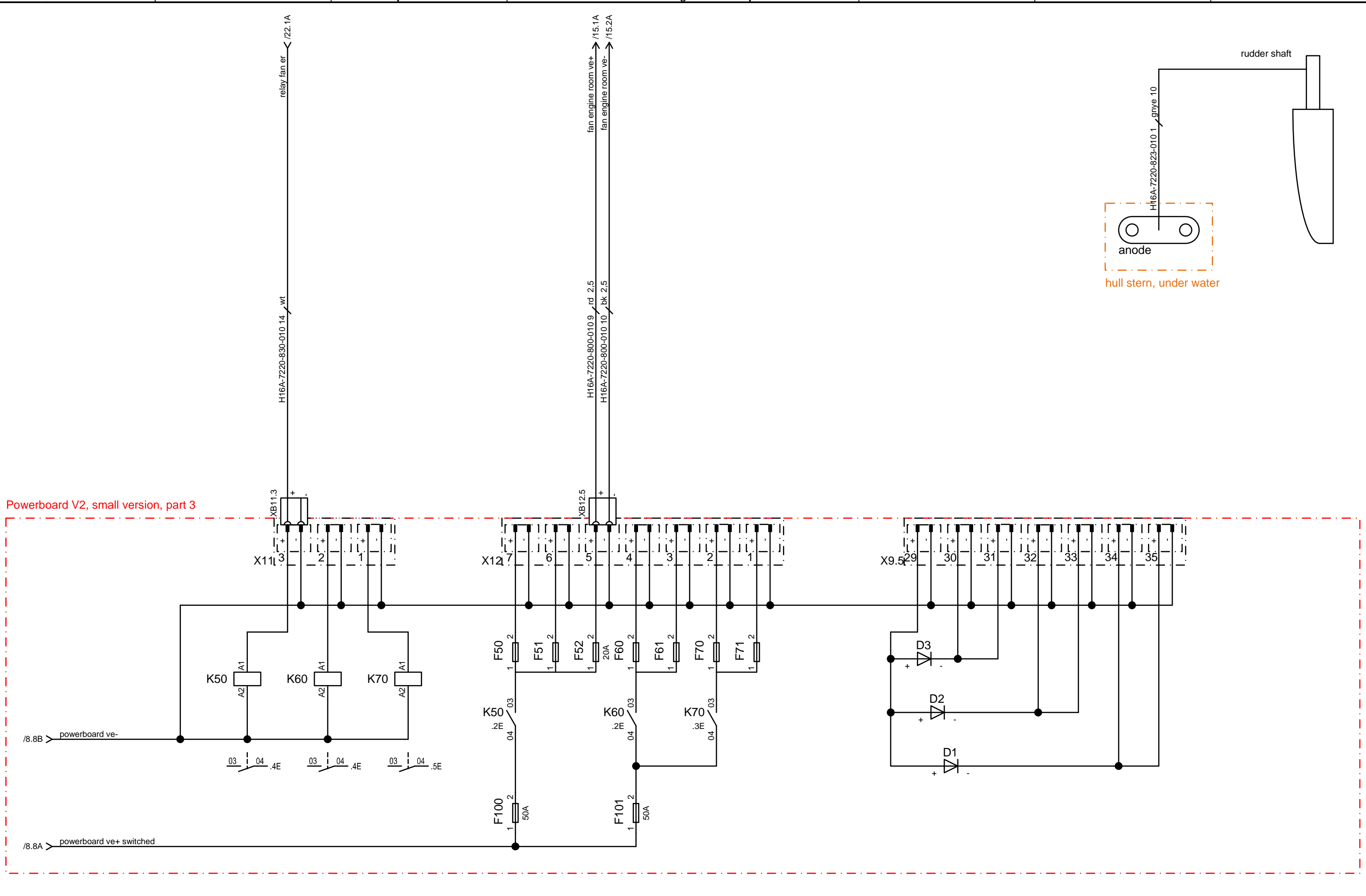

Powerboard V2, small version, part 3

01	new Sentinel Boats Monitor	26.06.2019	DW	Datum	24.07.2017
00	release	02.01.2018	JT	Gezeichnet	B. Gladrow
				Geprüft	T. Stein
Rev.	Änderung	Datum	Name	Genehmigt	T. Stein



Hanse Yachts AG
Salinenstr. 22
17489 Greifswald

DC Circuits
Powerboard Part 3

Hanse 348		H16A-7215-100-010 - 01		Blatt: 9	
				von 26 Bl.	

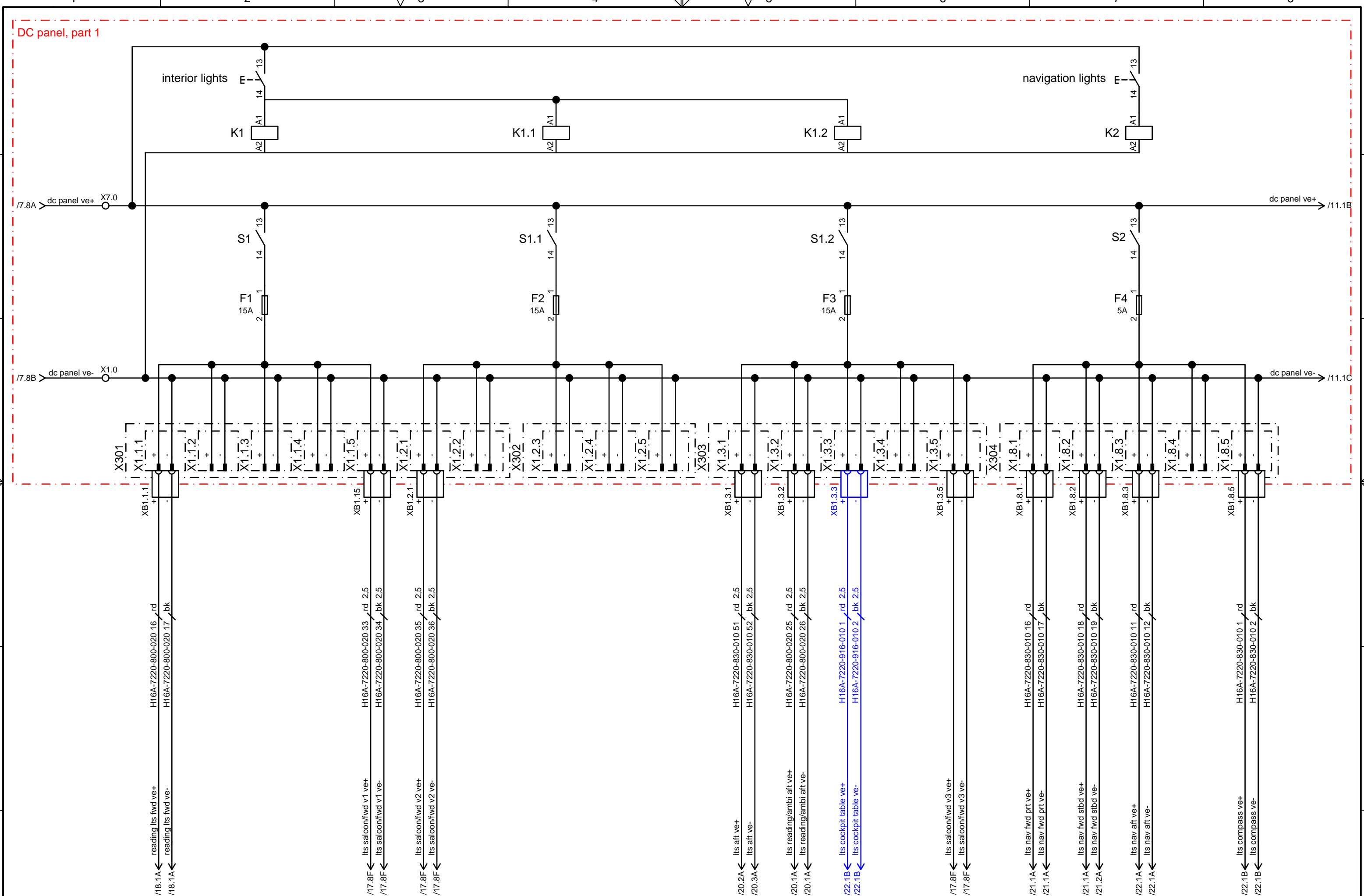

01	new Sentinel Boats Monitor	26.06.2019	DW	Datum	24.07.2017
00	release	02.01.2018	JT	Gezeichnet	B. Gladrow
				Geprüft	T. Stein
Rev.	Änderung	Datum	Name	Genehmigt	T. Stein



Hanse Yachts AG
Salinenstr. 22
17489 Greifswald

DC Circuits
DC Panel Part 2

Hanse 348		H16A-7215-100-010 - 01		Blatt:	10
				von	26
					Bl.

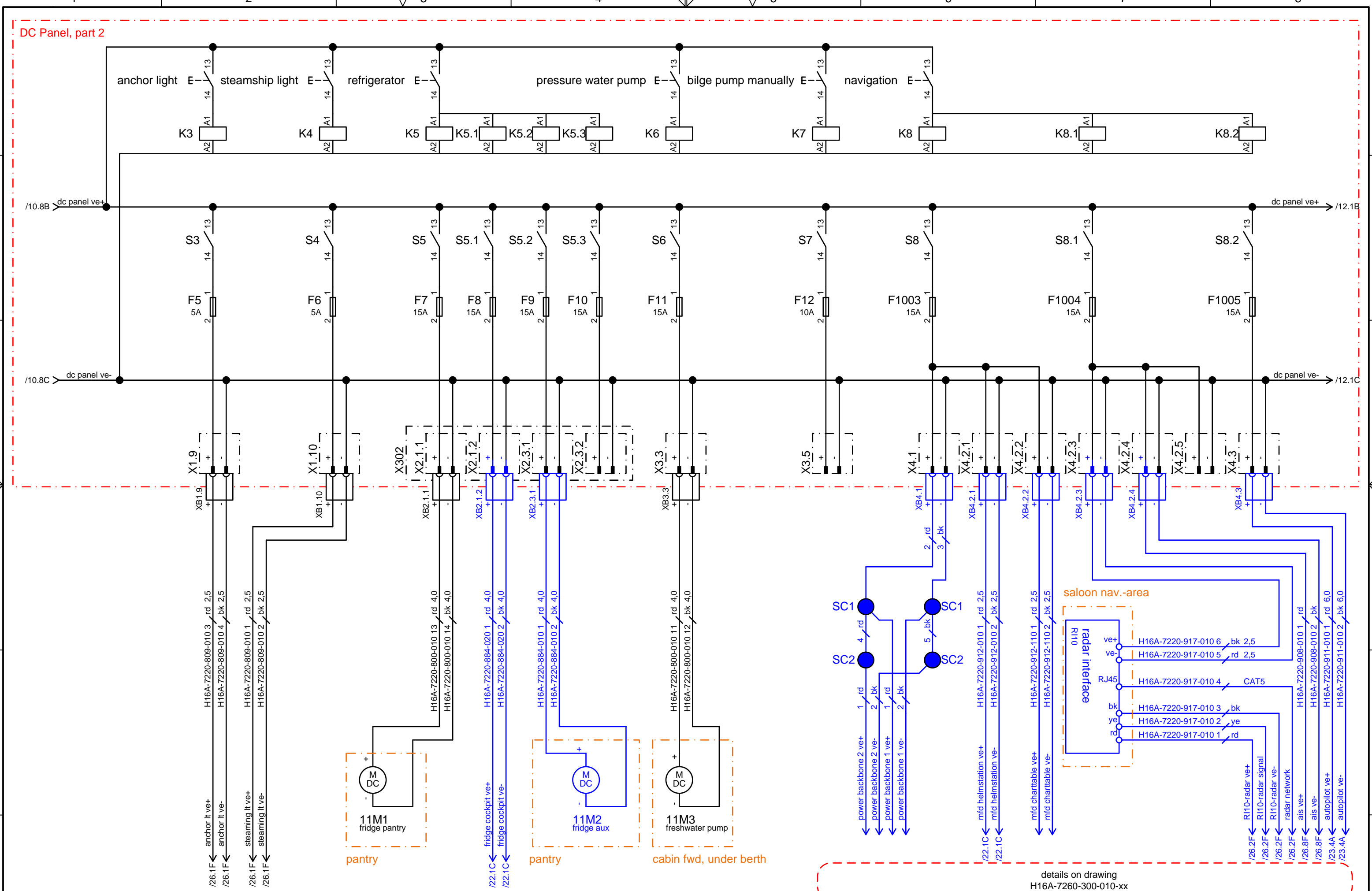

01	new Sentinel Boats Monitor	26.06.2019	DW	Datum	24.07.2017
00	release	02.01.2018	JT	Gezeichnet	B. Gladrow
Rev.	Änderung	Datum	Name	Geprüft	T. Stein
				Genehmigt	T. Stein

Hanse 

Hanse Yachts AG
Salinenstr. 22
17489 Greifswald

DC Circuits
DC Panel Part 2

Hanse 348		H16A-7215-100-010 - 01		Blatt: 11
				von 26 Bl.

DC panel, part 3

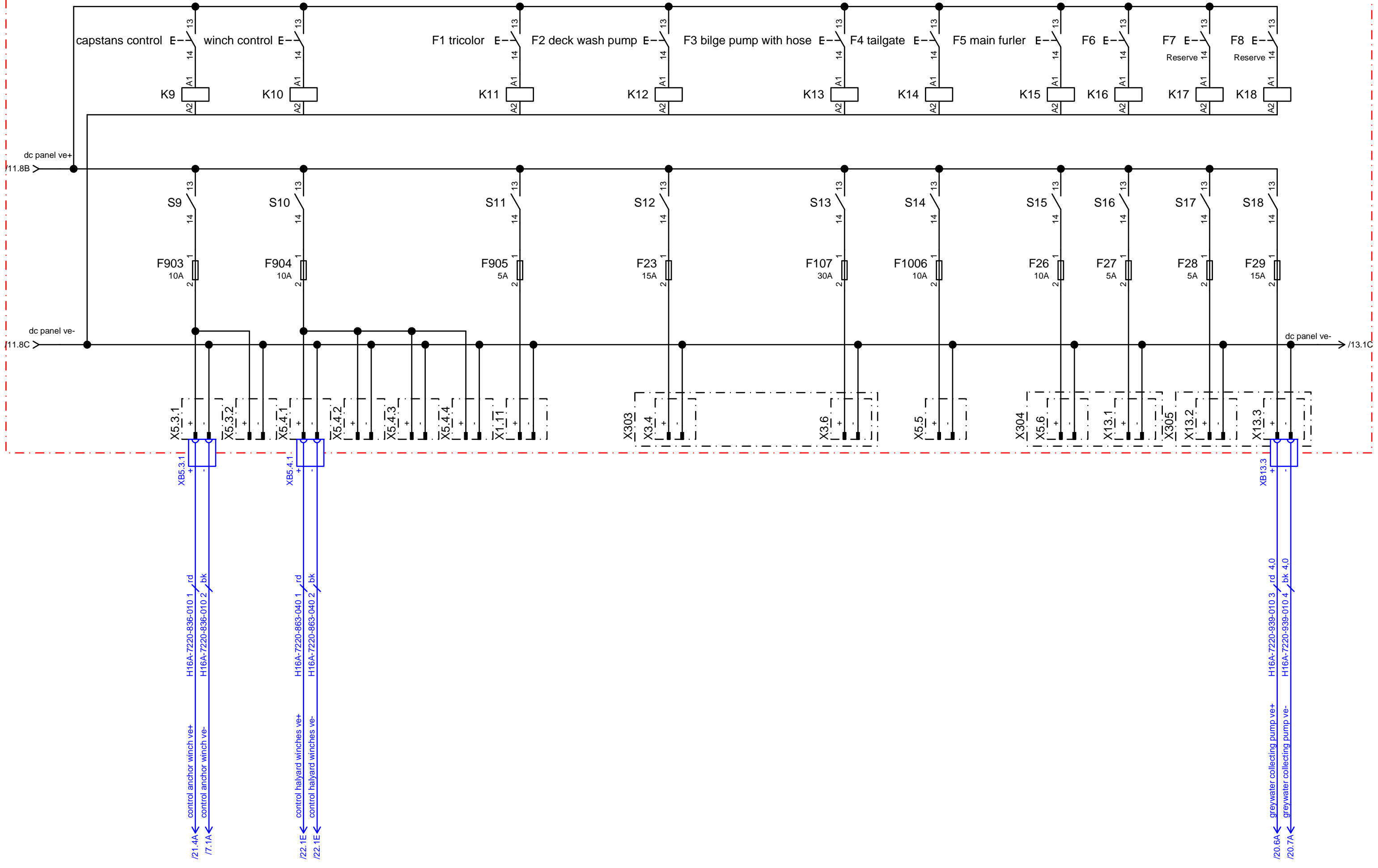

01	new Sentinel Boats Monitor	26.06.2019	DW	Datum	24.07.2017
00	release	02.01.2018	JT	Gezeichnet	B. Gladrow
				Geprüft	T. Stein
Rev.	Änderung	Datum	Name	Genehmigt	T. Stein



Hanse Yachts AG
Salinenstr. 22
17489 Greifswald

DC Circuits
DC Panel Part 3

Hanse 348

H16A-7215-100-010 -01

Blatt: 12
von 26 Bl.

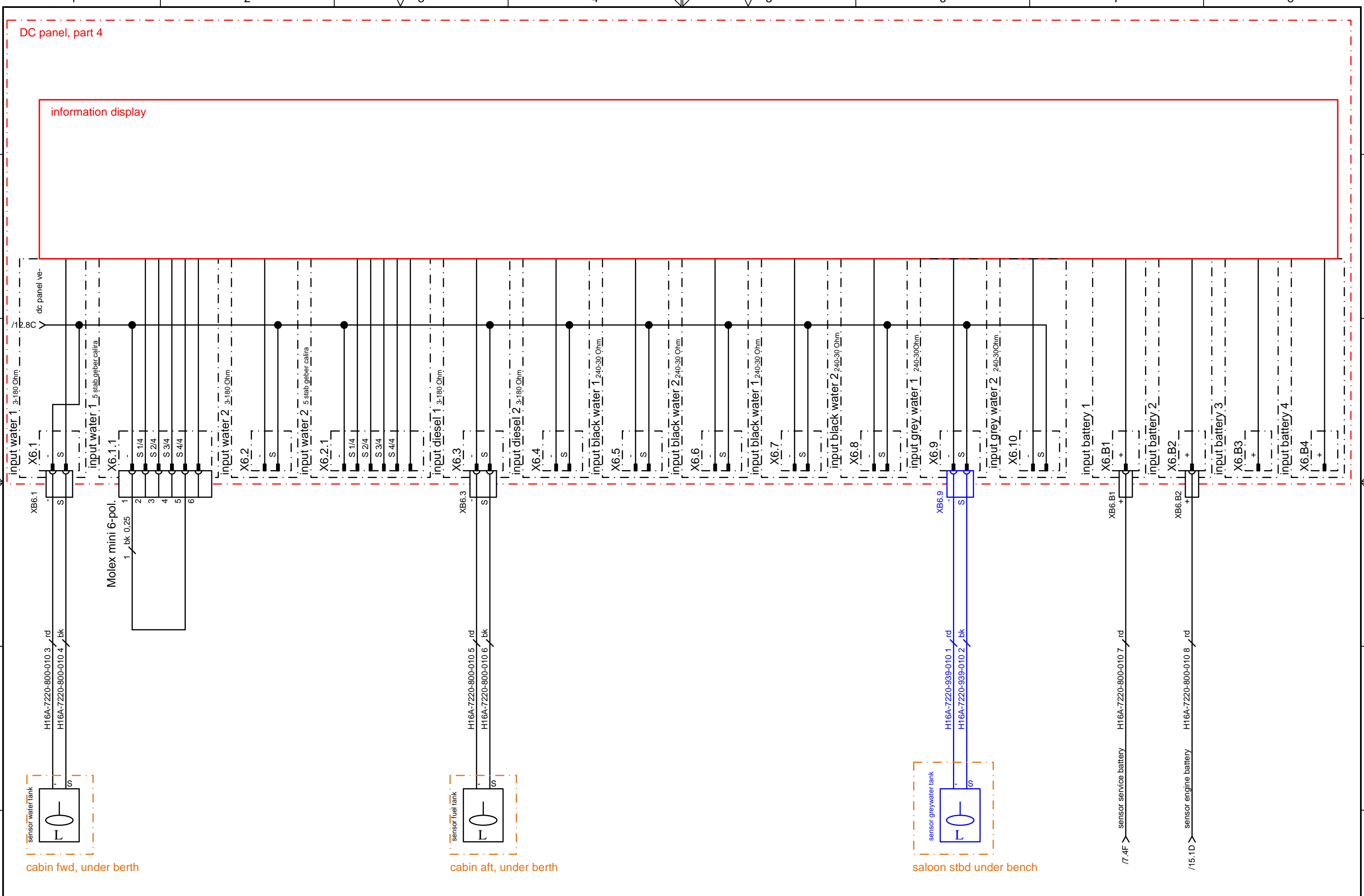

01	new Sentinel Boats Monitor	26.06.2019	DW	Datum	24.07.2017
00	release	02.01.2018	JT	Gezeichnet	B. Gladrow
				Geprüft	T. Stein
Rev.	Änderung	Datum	Name	Genehmigt	T. Stein



Hanse Yachts AG
Salinenstr. 22
17489 Greifswald

DC Circuits
DC Panel Part 4

Hanse 348		H16A-7215-100-010 - 01		Blatt: 13
				von 26 Bl.

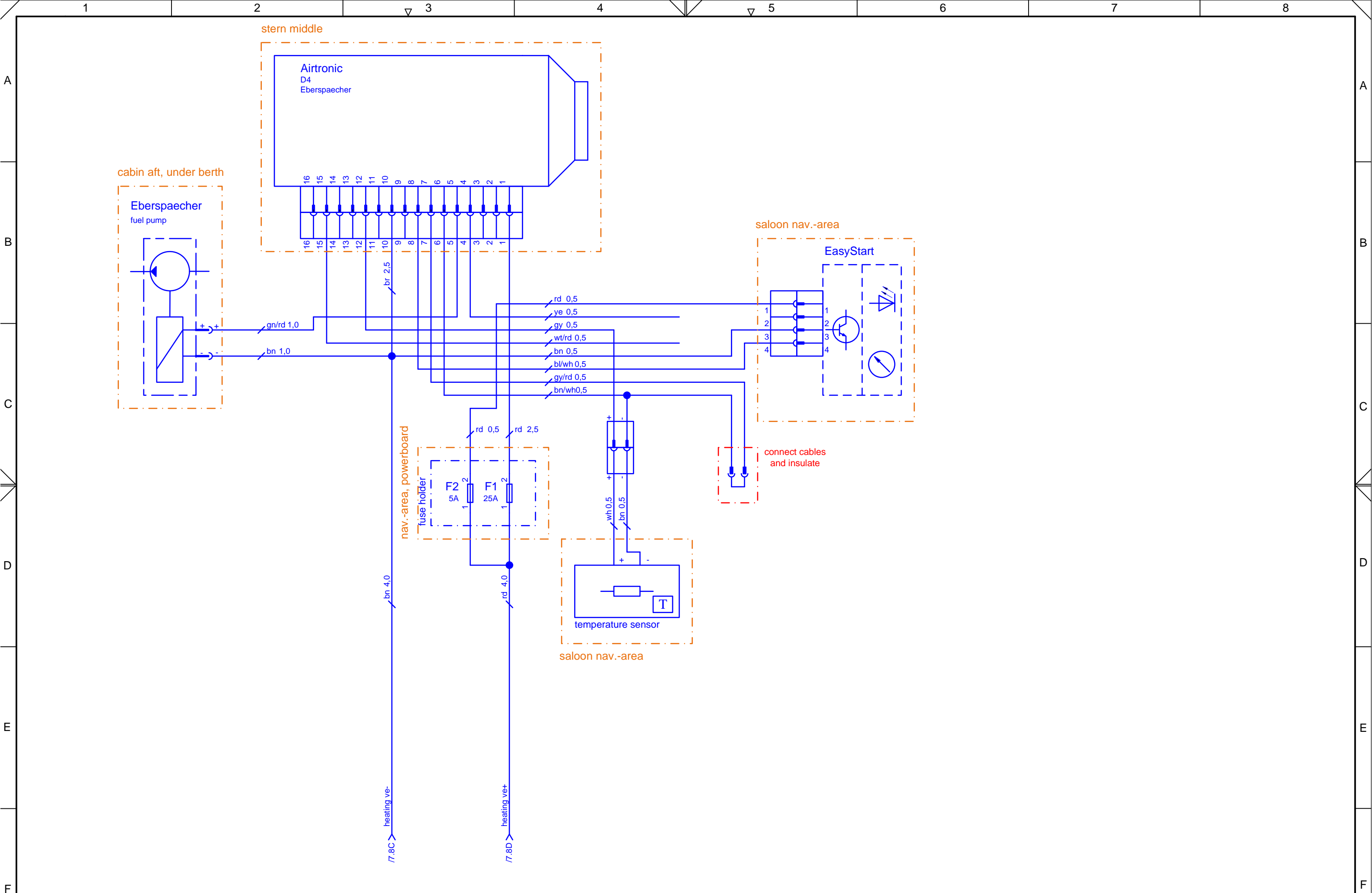

01	new Sentinel Boats Monitor	26.06.2019	DW	Datum	25.07.2017
00	release	02.01.2018	JT	Gezeichnet	B. Gladrow
				Geprüft	T. Stein
Rev.	Änderung	Datum	Name	Genehmigt	T. Stein



Hanse Yachts AG
Salinenstr. 22
17489 Greifswald

DC Circuits
Heating

=			
+			
Hanse 348	H16A-7215-100-010 -01	Blatt:	14
		von 26	Bl.

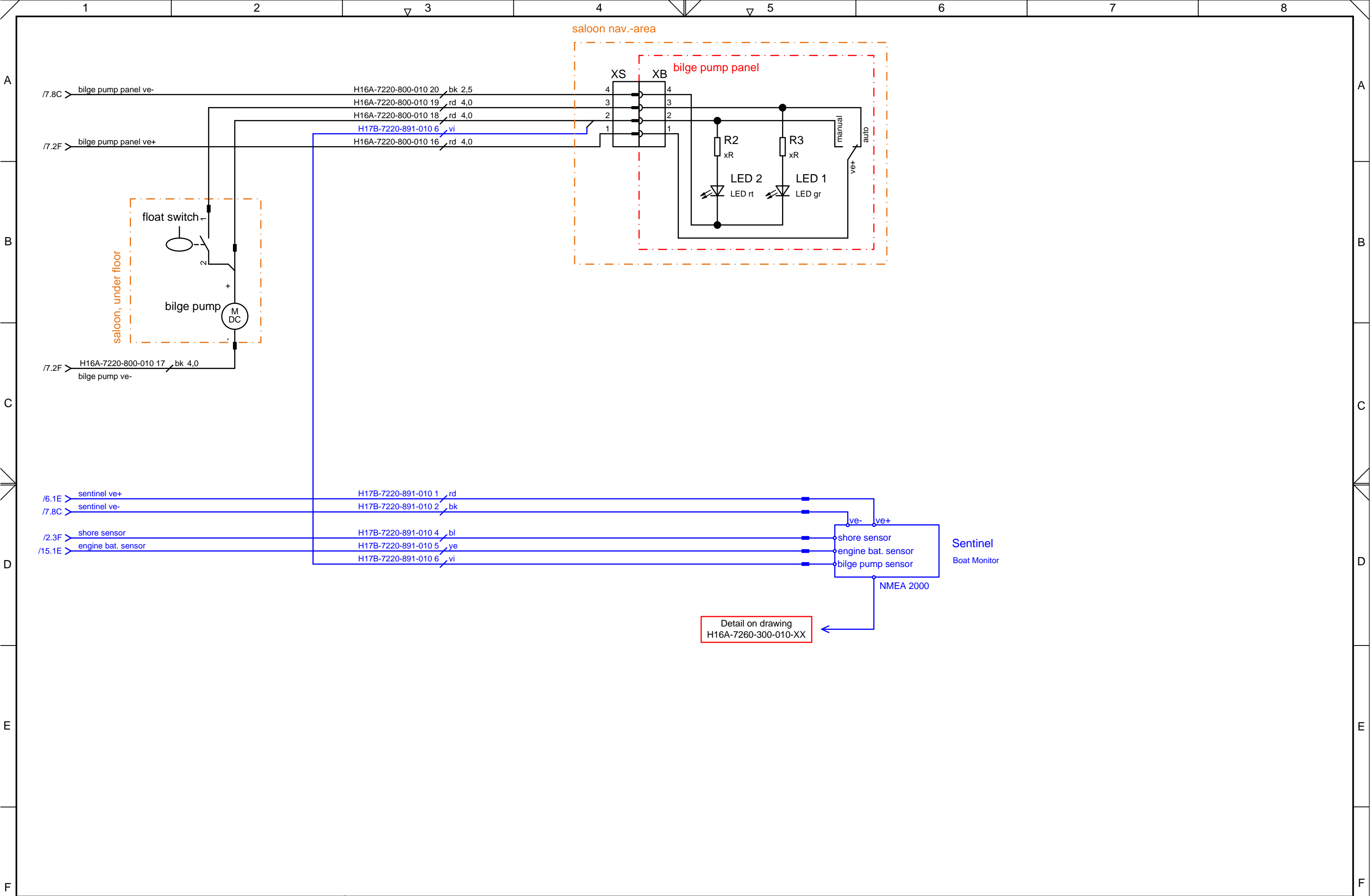

01	new Sentinel Boats Monitor	26.06.2019	DW	Datum	25.07.2017		Hanse Yachts AG Salinenstr. 22 17489 Greifswald	DC Circuits Bilge Pump Panel, Sentinel	= +	Hanse 348	H16A-7215-100-010 -01	Blatt:	16
00	release	02.01.2018	JT	Gezeichnet	B. Gladrow							von	26
Rev.	Änderung	Datum	Name	Genehmigt	T. Stein								

SLS control box saloon

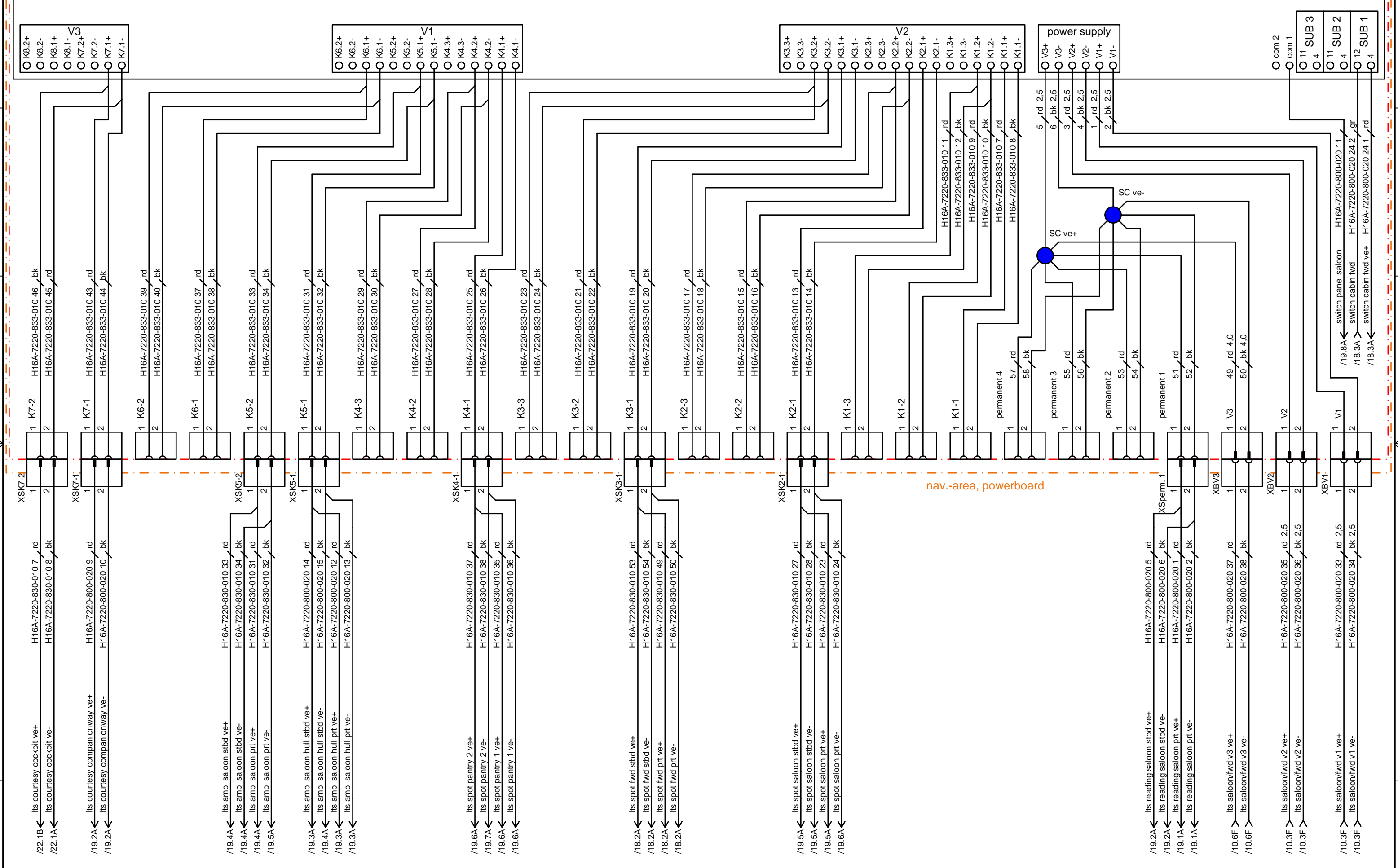

01	new Sentinel Boats Monitor	26.06.2019	DW	Datum	25.07.2017
00	release	02.01.2018	JT	Gezeichnet	B. Gladrow
				Geprüft	T. Stein
Rev.	Änderung	Datum	Name	Genehmigt	T. Stein



Hanse Yachts AG
Salinenstr. 22
17489 Greifswald

DC Circuits
SLS Control Box Saloon

Hanse 348		H16A-7215-100-010 - 01		Blatt: 17
				von 26 Bl.

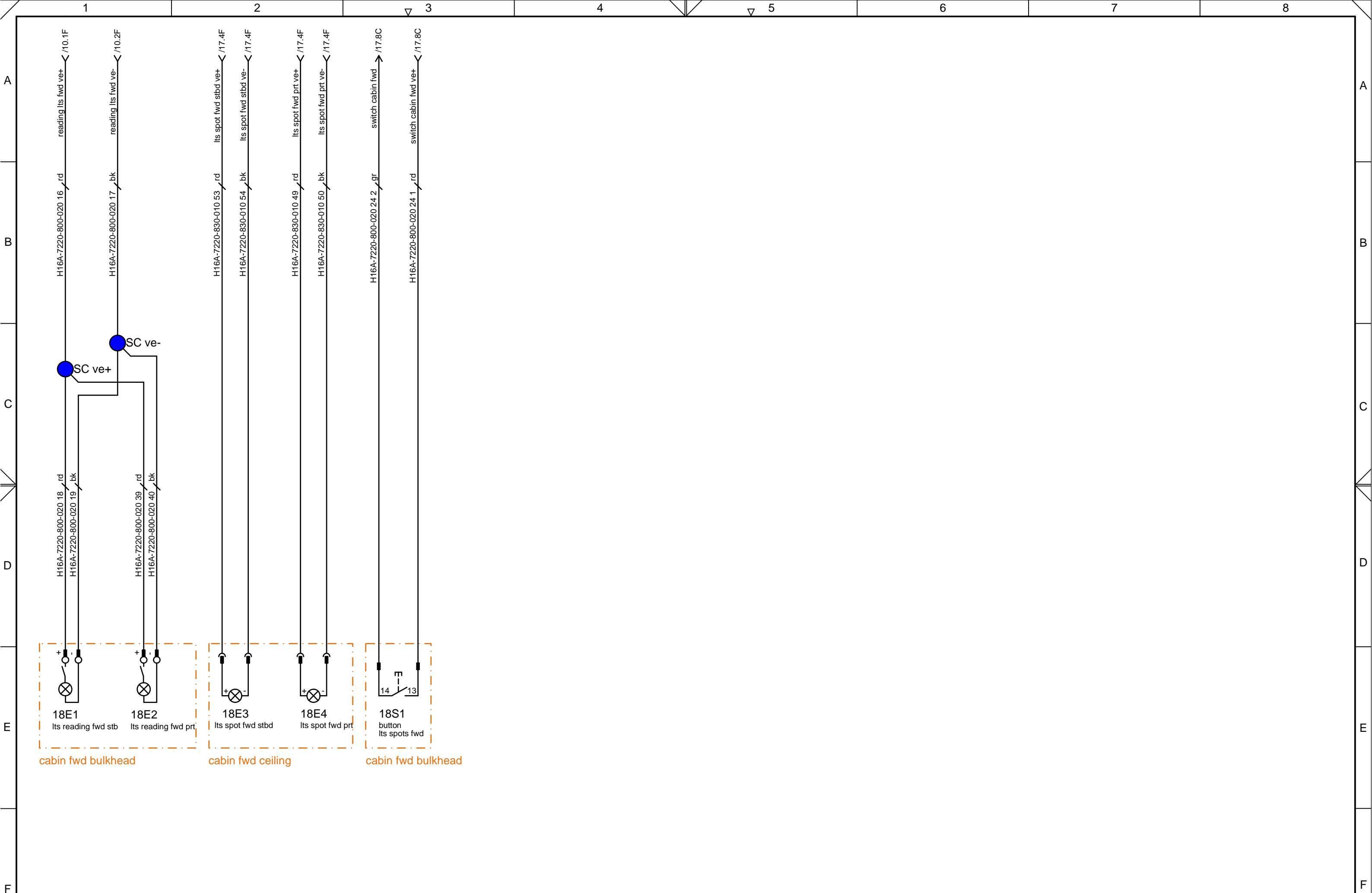

cabin fwd bulkhead cabin fwd ceiling cabin fwd bulkhead

01	new Sentinel Boats Monitor	26.06.2019	DW	Datum	26.07.2017
00	release	02.01.2018	JT	Gezeichnet	B. Gladrow
				Geprüft	T. Stein
Rev.	Änderung	Datum	Name	Genehmigt	T. Stein



Hanse Yachts AG
Salinenstr. 22
17489 Greifswald

DC Circuits
Lights Cabin fwd

=		Blatt: 18
+		
Hanse 348	H16A-7215-100-010 - 01	von 26 Bl.

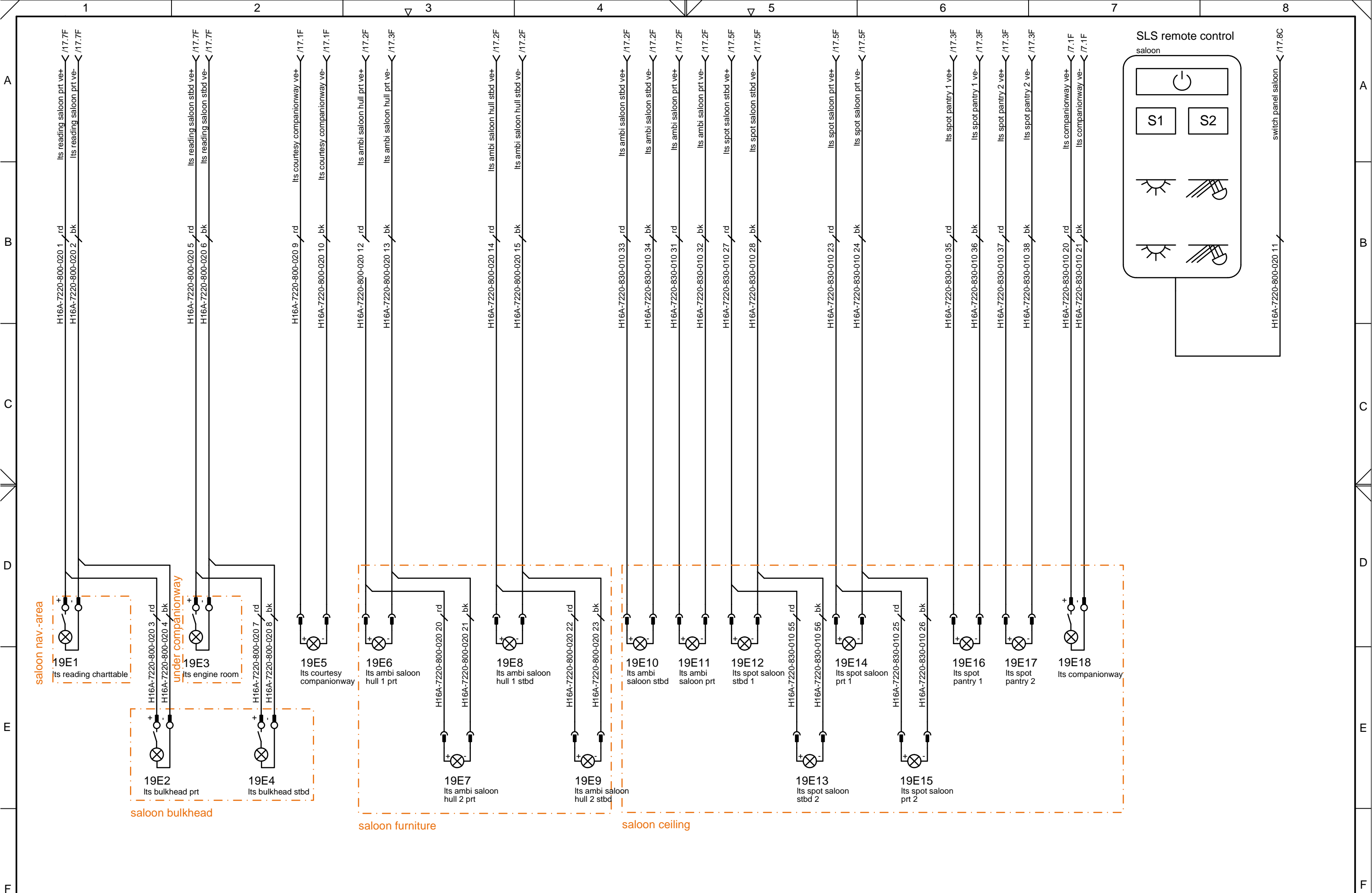

01	new Sentinel Boats Monitor	26.06.2019	DW	Datum	26.07.2017
00	release	02.01.2018	JT	Gezeichnet	B. Gladrow
				Geprüft	T. Stein
Rev.	Änderung	Datum	Name	Genehmigt	T. Stein



Hanse Yachts AG
Salinenstr. 22
17489 Greifswald

DC Circuits
Lights Saloon / Pantry

=		Blatt: 19
+		
Hanse 348	H16A-7215-100-010 - 01	von 26 Bl.

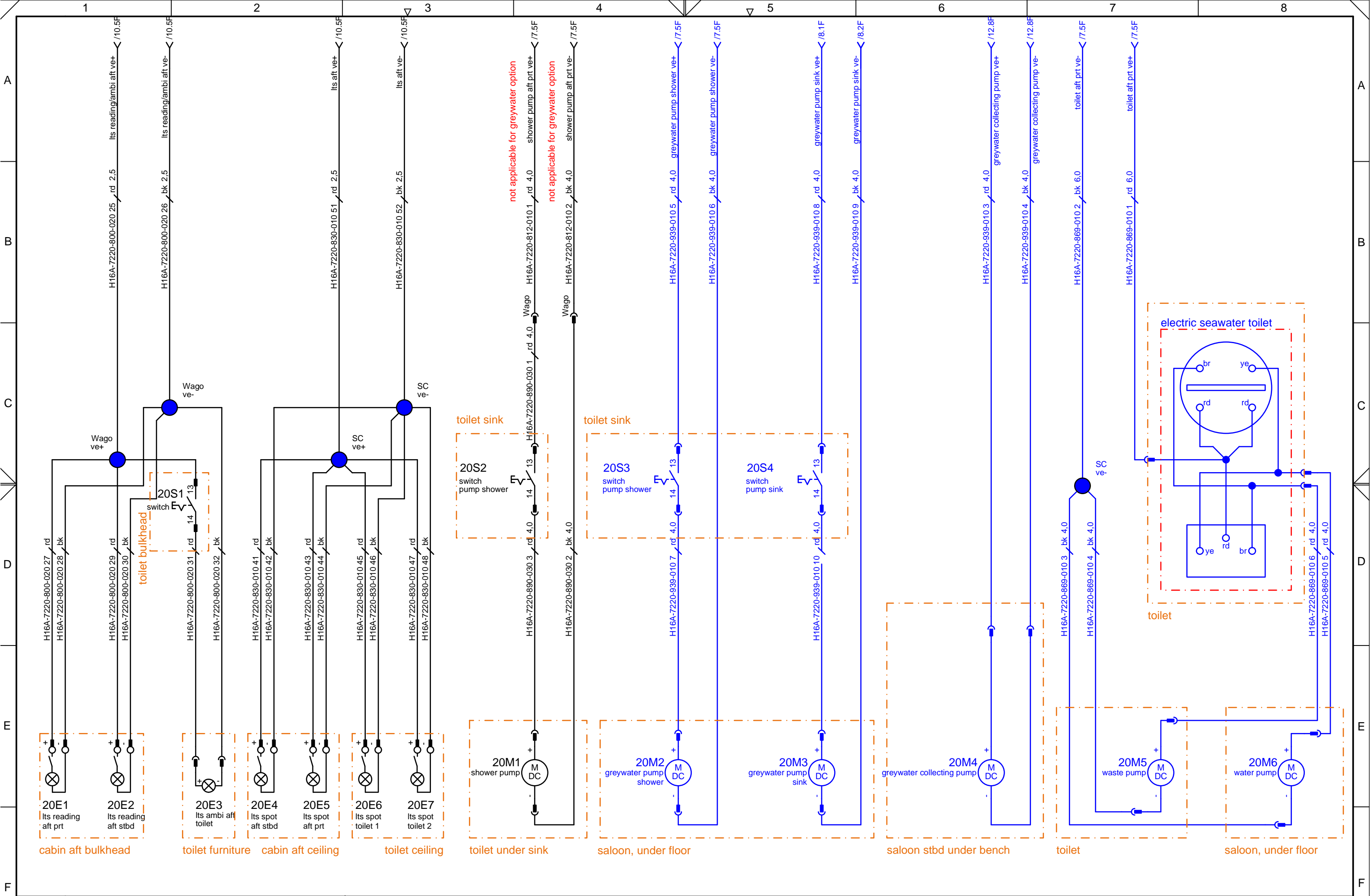

01	new Sentinel Boats Monitor	26.06.2019	DW	Datum	27.07.2017
00	release	02.01.2018	JT	Gezeichnet	B. Gladrow
				Geprüft	T. Stein
Rev.	Änderung	Datum	Name	Genehmigt	T. Stein



 Hanse Yachts AG
 Salinenstr. 22
 17489 Greifswald

DC Circuits
Lights aft, electric Toilet

Hanse 348	H16A-7215-100-010 - 01	Blatt: 20
		von 26 Bl.

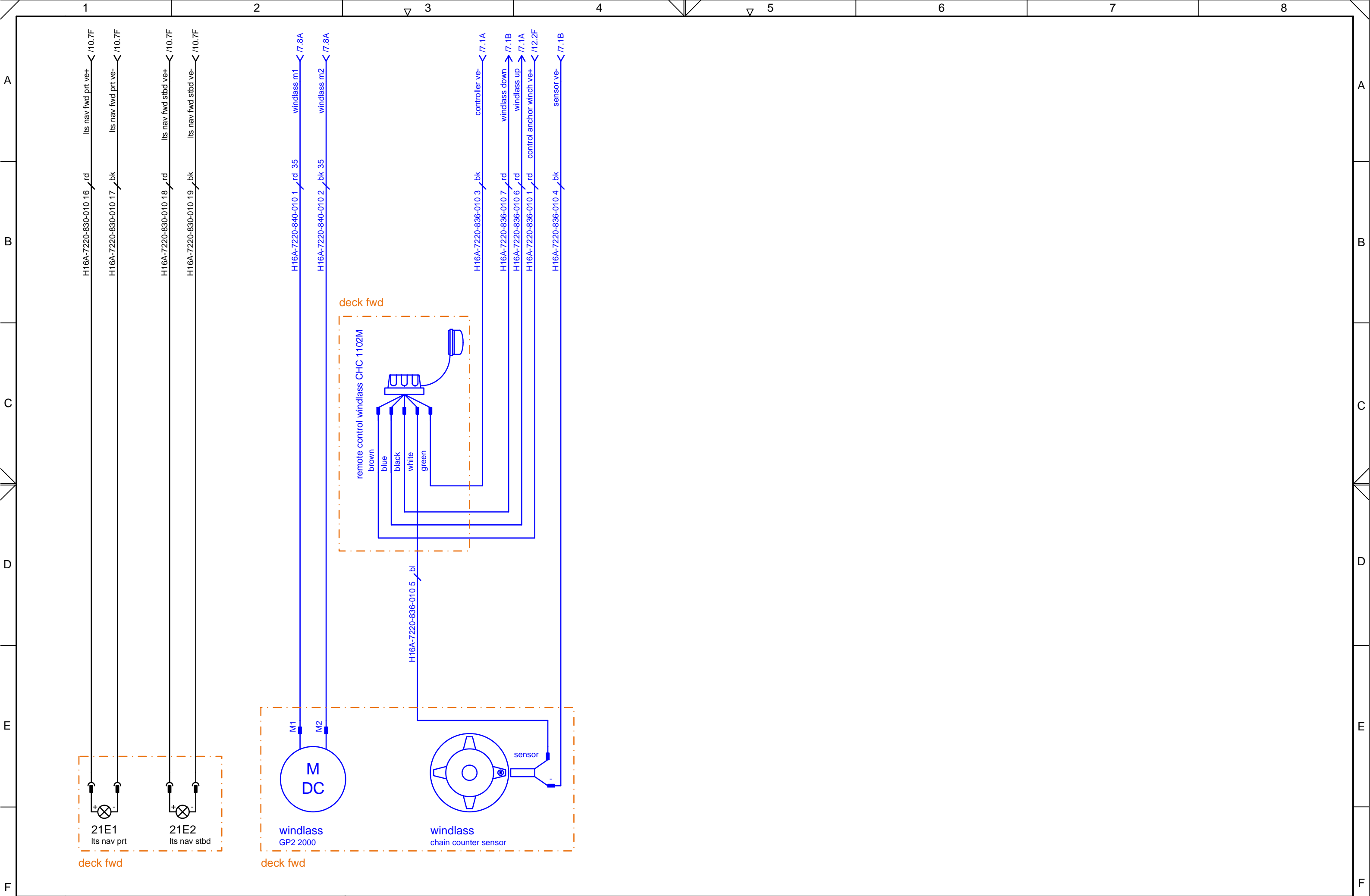

01	new Sentinel Boats Monitor	26.06.2019	DW	Datum	31.07.2017
00	release	02.01.2018	JT	Gezeichnet	B. Gladrow
				Geprüft	T. Stein
Rev.	Änderung	Datum	Name	Genehmigt	T. Stein



Hanse Yachts AG
Salinenstr. 22
17489 Greifswald

DC Circuits
Deck fwd

Hanse 348		H16A-7215-100-010 - 01		Blatt: 21
				von 26 Bl.

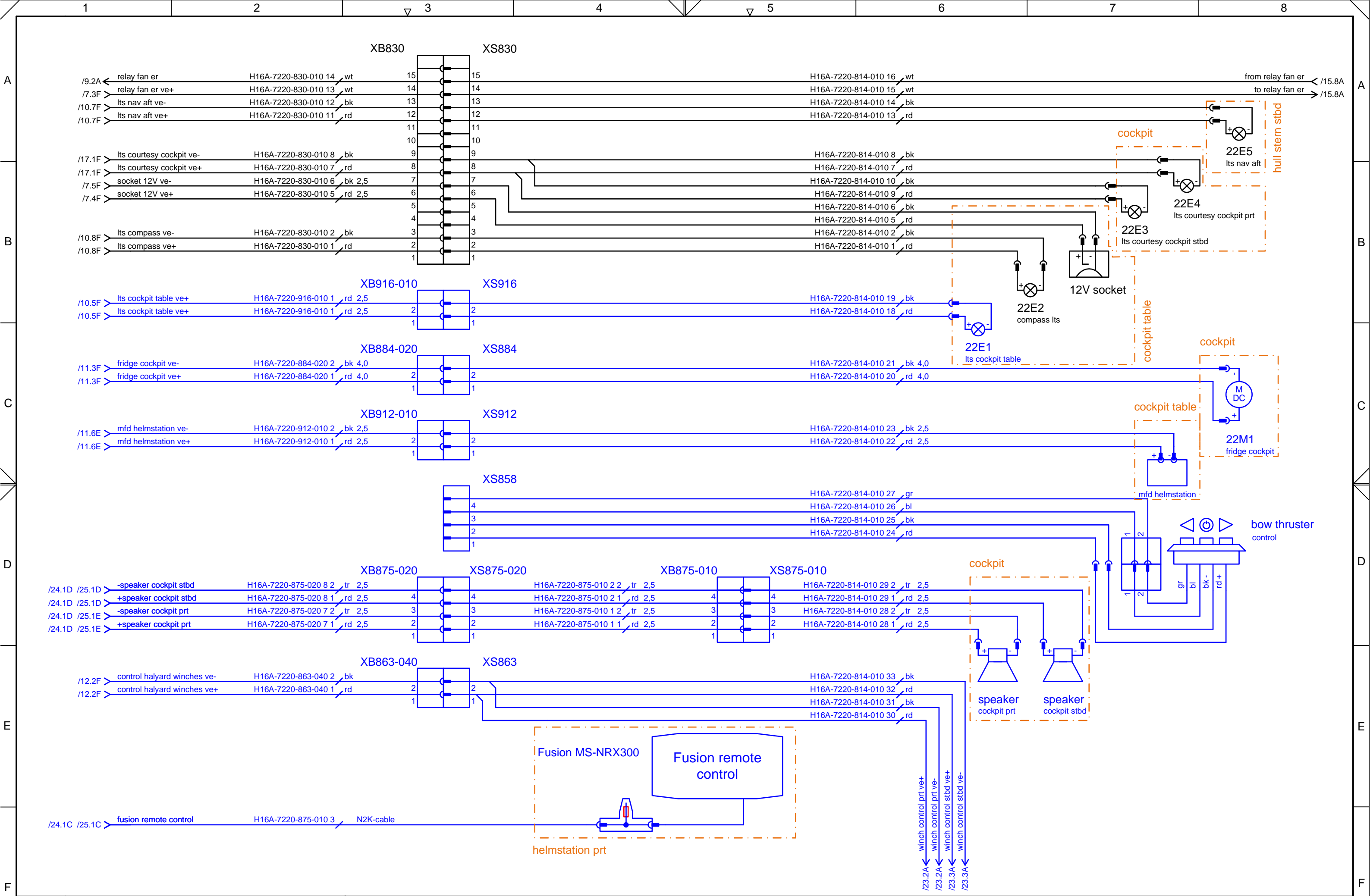

01	new Sentinel Boats Monitor	26.06.2019	DW	Datum	31.07.2017
00	release	02.01.2018	JT	Gezeichnet	B. Gladrow
				Geprüft	T. Stein
Rev.	Änderung	Datum	Name	Genehmigt	T. Stein

 Hanse Yachts AG
 Salinenstr. 22
 17489 Greifswald

DC Circuits
 Cockpit

Hanse 348 **H16A-7215-100-010 - 01**

Blatt: 22
 von 26 Bl.

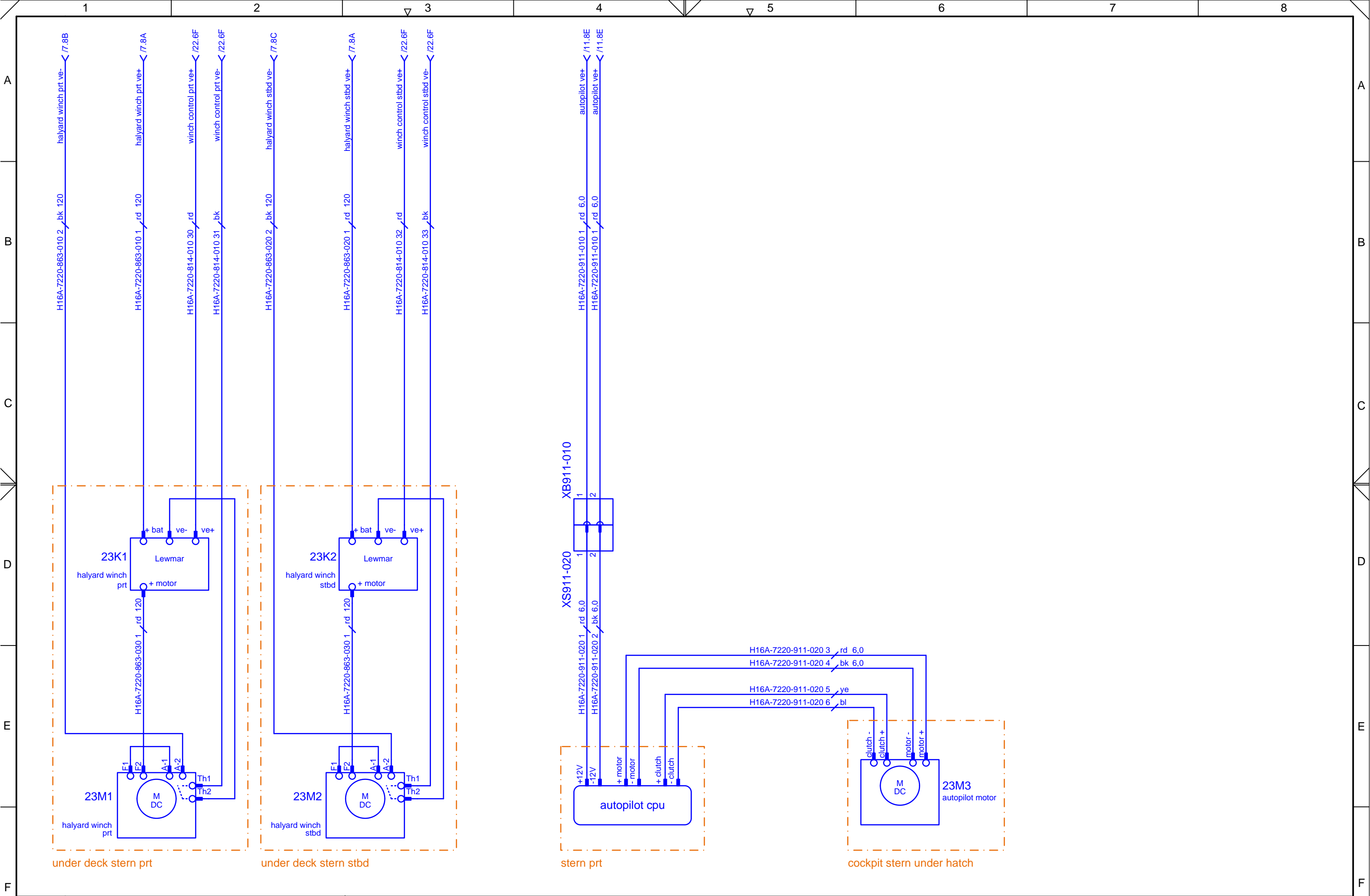

01	new Sentinel Boats Monitor	26.06.2019	DW	Datum	04.08.2017
00	release	02.01.2018	JT	Gezeichnet	B. Gladrow
				Geprüft	T. Stein
Rev.	Änderung	Datum	Name	Genehmigt	T. Stein



Hanse Yachts AG
Salinenstr. 22
17489 Greifswald

DC Circuits
Winches, Autopilot

=			
+			
Hanse 348		H16A-7215-100-010 - 01	
		Blatt: 23	
		von 26 Bl.	

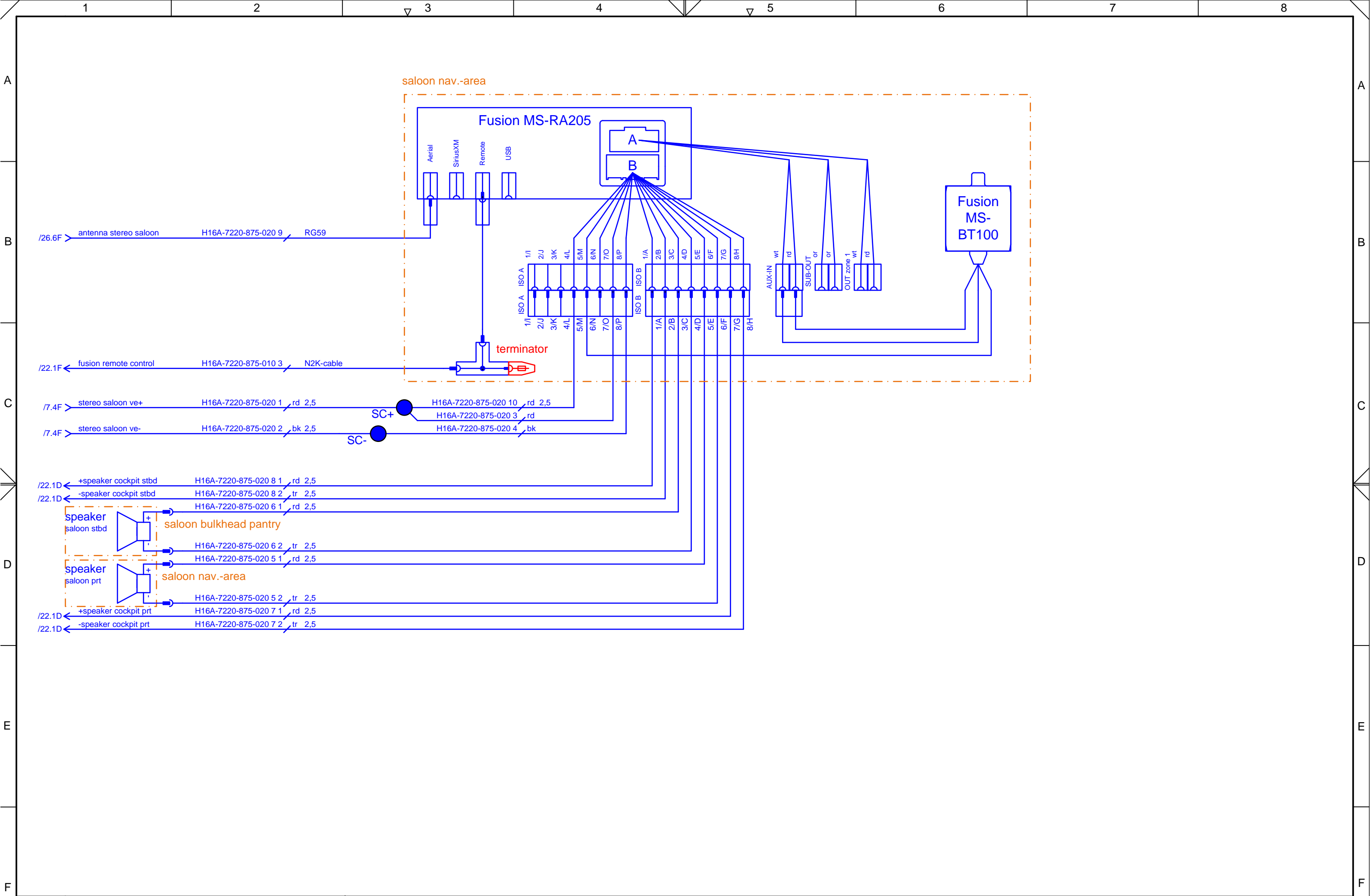

01	new Sentinel Boats Monitor	26.06.2019	DW	Datum	04.08.2017
00	release	02.01.2018	JT	Gezeichnet	B. Gladrow
				Geprüft	T. Stein
Rev.	Änderung	Datum	Name	Genehmigt	T. Stein



Hanse Yachts AG
Salinenstr. 22
17489 Greifswald

DC Circuits
Stereo Saloon

=			
+			
Hanse 348	H16A-7215-100-010 -01	Blatt:	24
		von	26

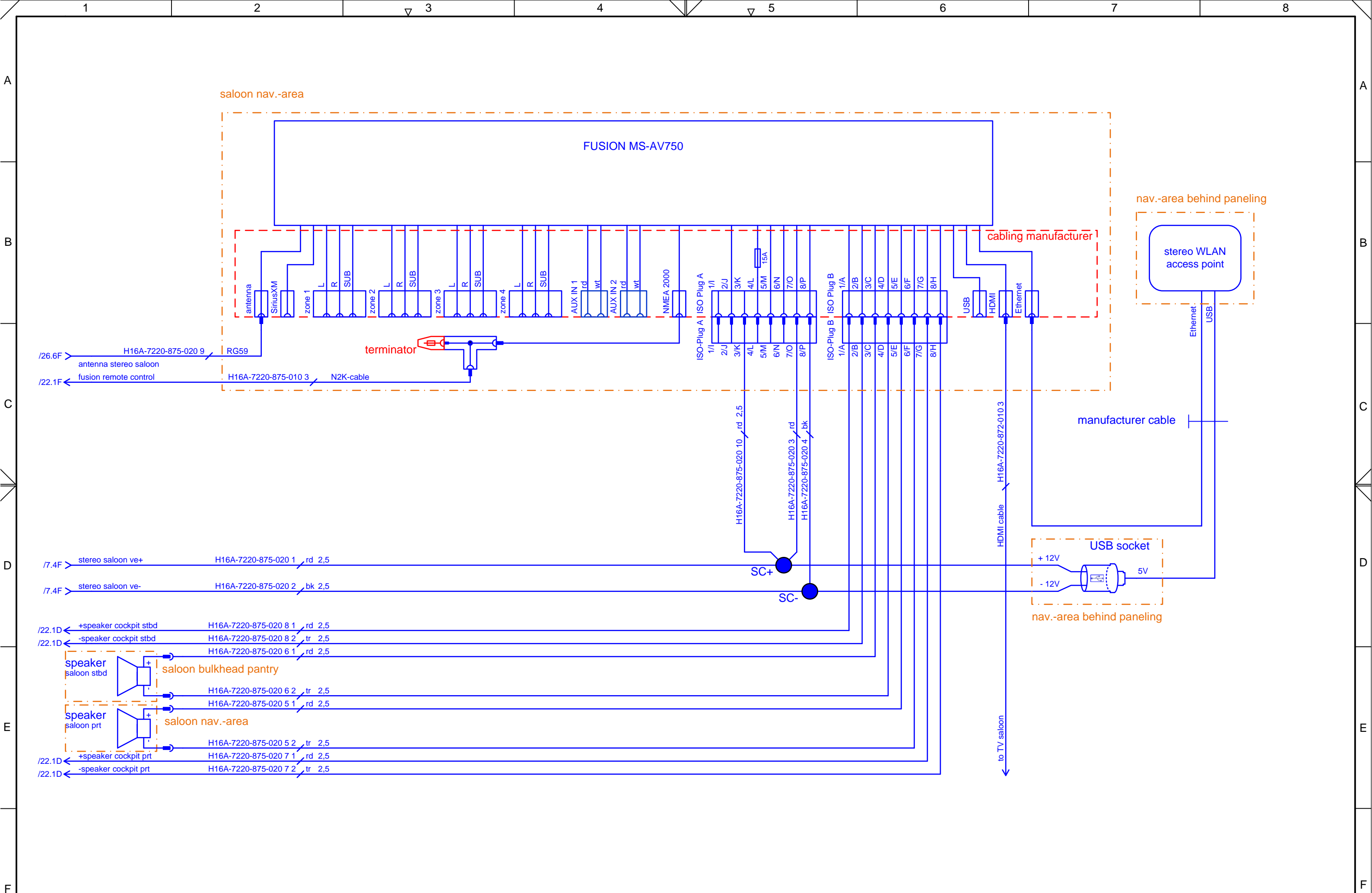

01	new Sentinel Boats Monitor	26.06.2019	DW	Datum	04.08.2017
00	release	02.01.2018	JT	Gezeichnet	B. Gladrow
				Geprüft	T. Stein
Rev.	Änderung	Datum	Name	Genehmigt	T. Stein



Hanse Yachts AG
Salinenstr. 22
17489 Greifswald

DC Circuits
Stereo Saloon Upgrade

Hanse 348		H16A-7215-100-010 -01		Blatt: 25
				von 26 Bl.

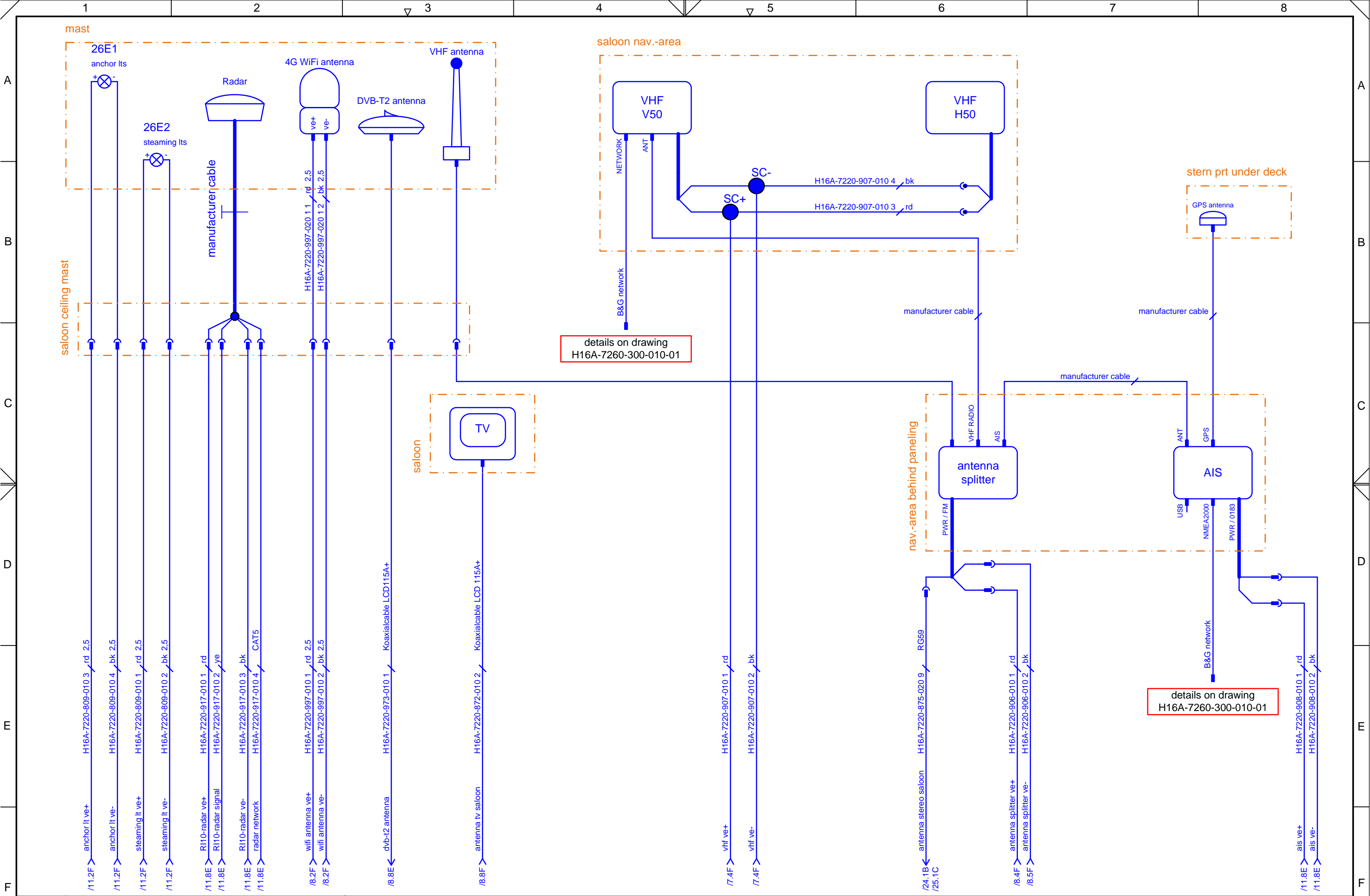

01	new Sentinel Boats Monitor	26.06.2019	DW	Datum	08.09.2017
00	release	02.01.2018	JT	Gezeichnet	B. Gladrow
				Geprüft	T. Stein
Rev.	Änderung	Datum	Name	Genehmigt	T. Stein



Hanse Yachts AG
Salinenstr. 22
17489 Greifswald

DC Circuits
Mast, Antenna

=		Blatt: 26	
+		von 26 Bl.	
Hanse 348	H16A-7215-100-010 - 01		